

DECLARATION OF CONFORMITY OF THE SUPPLIER - CE

We: Zakład Produkcyjno Usługowy „AGRO-WIKT” Jan Wiktorowicz [Production-Service Plant AGRO-WIKT Jan Wiktorowicz] 26-300 Opoczno, ul. Zakątna 4 declare, with full responsibility, that the product:
Gravity Concrete Mixer

Type - BWA-200 ; BWA-150 ; BWA-110 ; BWA-80

Polish Classification of Products and Services Number: 29.52.40-50.90-00

Systematic Nomenclature of Goods Number: 0812-21

powered by means of electrical engine, is intended for the production of concrete and masonry mortars.

The product described above is in conformance with the following standards:

PN-EN-292-1;-2:2000

PN-EN-60204-1:2001

PN-EN-60335-1:1999

PN-ISO-3600:1998

PN-ISO-11684:1998

We declare conformance with the following requirements:

Directive 98/37/WE

Directive 73/23/EWG

Directive 89/336/EWG

Directive 200/14/WE

The technical documentation is available at the head office of Z.P.U. „AGRO-WIKT” Bukowiec Opoczyński 27 at the Main Engineer.

Place and date of issue

Opoczno, 2009

Signature-position

Jan Wiktorowicz-Owner

Quality claims must be reported to the manufacturer exclusively.

Before you call service.....

The most frequent cause of failure of the engine and the electrical system are unauthorised and defective modifications.

Replacement of the power plug with another, without the consent of the manufacturer, causes the guarantee to become invalid.

We would like to remind you that in the case of unnecessary call-out of service, the customer covers the costs of arrival and work of the service unit.

The guarantee does not cover:

- spare parts listed in the manual, which become worn out during operation,
- any mechanical damage and defects caused by the aforementioned spare parts,
- lack of observance of the instructions given in the manual during the start-up, service, maintenance, operation and storage of the concrete mixer,
- unauthorised repairs and modifications of the device,
- damage to the engine and switch caused by an inefficient electrical system.

I hereby declare that I have become familiar with the operating manual and the guarantee for the concrete mixer.

ZPU "AGRO-WIKT"

Complaint coupon No. 1

Date of reporting the complaint

The complaint refers to:

User's data

.....

ZPU "AGRO-WIKT"

Description of performed repair No. 1

Date of repair

Repair referred to.....

ZPU "AGRO-WIKT"

Complaint coupon No. 2

Date of reporting the complaint

The complaint refers to:

User's data

.....

ZPU "AGRO-WIKT"

Description of performed repair No. 2

Date of repair

Repair referred to:.....

DECLARATION OF CONFORMITY

in accordance with Directive 2000/14/WE, according to Procedure M/0096/00/Uż
MGPi PS dated 02.07.2003

We:	Zakład Produkcyjno Usługowy AGRO – WIKT [Production-Service Plant AGRO-WIKT]
Supplier	Jan Wiktorowicz
Address:	26-300 Opoczno, ul. Zakątna 4

We declare that the sound power of the noise emitted into the atmosphere by concrete mixers of the following types: **BWA-200 ; BWA-150 ; BWA-110 ; BWA-80** amounts to:

Concrete mixer type	BWA- 200	BW - 150	BWA- 110	BWA- 80
<i>Measured sound power level L_{wa}= dB (A)</i>	84	85	74	78
<i>Guaranteed sound power level L_{wa} ≤dB (A)</i>	87	87	77	77

The declared sound power is supported by tests performed by the **Construction Equipment Research Institute** – Research Design Centre in accordance with standard PN-EN ISO 3744:1999

Place and date of issue

Opoczno, 2009

Signature –position

Jan Wiktorowicz-Owner

TABLE OF CONTENTS:

1. Introduction	page 3
2. Purpose	page 3
3. Safety of use	page 3
4. Construction and principle of operation	page 4
4.1. Electrical system	page 5
5. Operating manual	page 7
5.1. Preparation for operation	page 7
5.2. Lubrication and maintenance	page 7
5.3. Finishing the operation.....	page 8
5.4. Replacement of spare parts	page 8
5.5. Repairs	page 8
6. Storage	page 9
7. Transport	page 9
8. Technical characteristics	page 9
9. Troubleshooting	page 10
10. Disassembly and decommissioning	page 10
11. List of spare parts.....	page 10
12. Warranty procedure regulations	page 13

NOTE:

1. *This operating manual constitutes the basic equipment of the concrete mixer.*
2. In the case that this manual is not understandable, refer to the manufacturer (the address is given on the cover page of the manual).



PN-EN ISO 9001

Zakład Produkcyjno - Usługowy
„AGRO-WIKT”
26 - 300 Opoczno
Ul. Zakątna 4
tel. / fax (44) 755-35-91

WARRANTY CARD

No.

GRAVITY CONCRETE MIXER
BWA-200 ; BWA-150 ; BWA-110 ; BWA-80 **

Year of manufacture

Product number

Date of sale

Electrical engine No.

Symbol KJ

.....
(stamp and signature of the seller)

** delete as appropriate

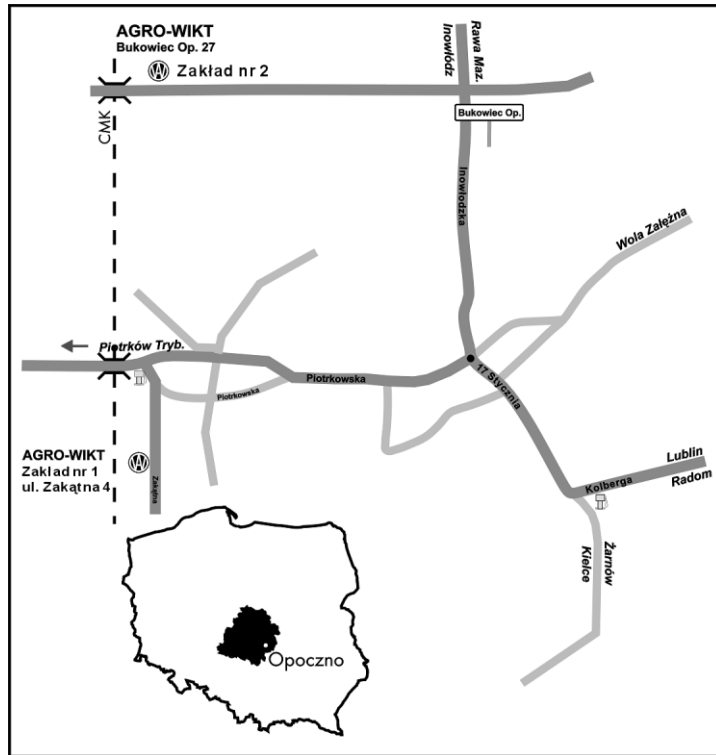

Access map for AGRO-WIKT.

The distributor of the spare parts is::

Z.P.U. "AGRO-WIKT"
 Wiktorowicz Jan
 Ul. Zakątna 4
 26-300 Opoczno

The standardised parts are available in specialist shops.

1. INTRODUCTION

We would like to congratulate you on the purchase of the high quality BWA gravity concrete mixer.

Before starting the operation of the machine, read the operating manual carefully. During operation, act in accordance with the instructions and safety rules given herein.

Before use, during use and after finishing the operations of the concrete mixer, maintain it in the due technical condition and appropriate cleanliness.

Use only original spare parts from the manufacturer to repair the concrete mixer. Any claims will not be recognised if the applied spare parts are different from the original ones. The unauthorised modifications introduced to the concrete mixer without the consent of the manufacturer exempt it from responsibility for any ensuing damage.

2. PURPOSE

The concrete mixer is intended for the production of concrete as well as masonry mortars and plastering mortars.

The concrete mixer should be used in accordance with its PURPOSE.





3. SAFETY OF USE

The concrete mixer may be used by an adult person who is accurately familiar with this operating manual and the health and safety at work regulations.

During the operation of the concrete mixer:

- Do not start the concrete mixer without electrical shock protection – risk of electrical shock,
- Do not operate the concrete mixer when the guards are removed – risk of injury,
- It is prohibited to connect the concrete mixer to the mains, when the insulation of the electrical wires are worn or damaged – risk of electrical shock,
- Do not adjust the tension of the V-belt during the operation of the concrete mixer – risk of injury (during adjustment, disconnect the concrete mixer from the mains socket),
- Do not direct the water stream to the electrical systems of the product during the operation and cleaning of the concrete mixer – risk of electrical shock,
- Do not move the concrete mixer during operation or when it is live – risk of injury and electrical shock,
- Any work connected with repairs, maintenance and technical service may be performed only after the concrete mixer is disconnected from the mains, that is, after the power plug is removed from the electrical socket – risk of electrical shock,
- Any repairs and connections of the electrical system of the concrete mixer may only be performed by a qualified electrician,
- Do not put hands into the drum of the concrete mixer during its operation – risk of injury,
- During the shut-down and storage of the concrete mixer, disconnect the power plug of the connecting wire from the electrical mains socket.
- Do not touch the rotary elements of the machine during operation, especially the gear transmission and belt transmission.

The safety signs placed on the housing of the concrete mixer drive should always be clean and legible. In the case of their destruction or loss, replace them with new ones. They provide the following information:

1 – Read the operating manual	
2 – Ban on operating the concrete mixer by children	
3 – Do not connect the device to the mains in the case of damage to the connection or the socket.	
4 – Direction of drum revolution	
5 – All works related to repairs, maintenance and technical service must be performed only when the electrical system of the concrete mixer is disconnected (the plug is pulled out of the socket)	

The rating plate is located on the engine casing in a visible place. It specifies: the type of the concrete mixer, power and engine rated voltage, capacity, mass, current frequency, protection class, manufacture No. and year of manufacture. The information-warning signs may be acquired from the manufacturer or the dealer.

4. CONSTRUCTION AND PRINCIPLE OF OPERATION

The gravity concrete mixer is characterised by simple construction and easy operation. It consists of the following units:

- Main frame of the stand (fig. 1 item 1), to which two road wheels with a rubber tincture are fixed in the rear part
- Drum mixer (fig.1 item 2) placed on the axis bearing of the main frame of the stand

12. WARRANTY PROCEDURE REGULATIONS

The user is understood to be a natural or legal person acquiring the Gravity Concrete Mixer, the dealer is understood to be a commercial unit supplying the concrete mixer to the user and the manufacturer is to be understood as the maker of the concrete mixer.

The warranty for the Gravity Concrete Mixer is granted to the user for a period of 12 months starting from the date of purchase of the product. The warranty period may not exceed 18 months starting from the date of production.

The warranty covers all the elements of the concrete mixer, irrespective of the fact whether the manufacturer produced them in his own production site or received them within the framework of cooperation.

The guarantee does not cover:

- spare parts listed in the manual, which wear and tear naturally during operation,
- any mechanical damage and defects caused by them,
- non-observance of the instructions included in the manual with regard to starting, servicing, maintaining, operating and storing the concrete mixer,
- unauthorised repairs and modifications of the device,
- damage to the engine and switch caused by an inefficient electrical system.

Complaints must be reported to the manufacturer exclusively.

The basis for consideration of a complaint during the warranty period is the warranty card.

The product covered by the complaint is repaired within a period of 21 days from the date of reporting the complaint.

Authorisations resulting from the warranty do not cover the right of the user to pursue the return of lost benefits in relation to the failure of the device. The user bears the costs of any arrival of maintenance service staff and repair of the product that is not covered by the warranty.

NOTE: In the course of duration of and after the expiry of the warranty period, the manufacturer ensures free-of-charge polyamide sleeves (slide sleeves). The remaining elements which wear and tear naturally are available at the price of own costs.

NOTE: Failure to apply the instructions included in this operating manual may expose the operator of the machine to serious accident: electrical shock, damage to hands, permanent disability etc.

- drum tipping mechanism (fig. 1, item 3), whose action is possible owing to the worm gear with the manual drive knob,
- concrete mixer drive from the electrical engine (fig. 1 item 4) through the belt transmission and transmission gear,
- drive guards with the belt transmission (fig. 1, item 5) made of metal sheets
- a switch that switches the concrete mixer on and off (fig. 1., item 6)

The TRIPUS control device of the concrete mixer is attached to the engine casing (fig. 1, item 6). The green button serves the purpose of switching it on and the red button switches the control device off.

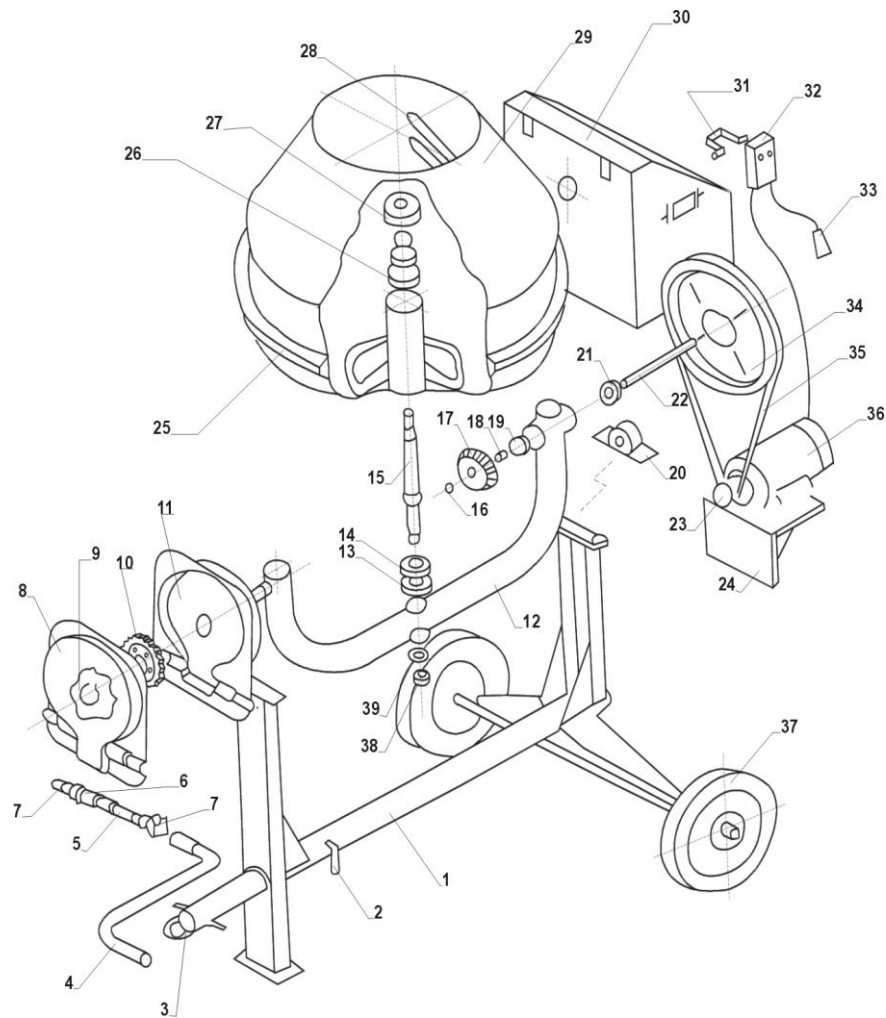

Figure 4.
BWA gravity concrete mixer

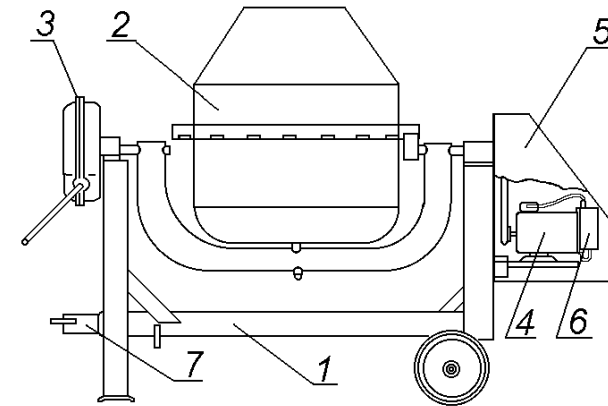

Figure No. 1
BWA gravity concrete mixer
Notations: 1 – main frame, 2 – concrete mixer drum, 3 – tipping mechanism,
4 – concrete mixer drive, 5 – drive cover, 6 - switch, 7 – drawbar.

4.1. Electrical system

The gravity concrete mixer is powered by a 3-phase engine or 1-phase engine with the connecting terminal finished with a plug. The electrical engine is protected from overload by an automatic thermal switch. The engine is switched on by pushing the green button (ON), and switched off by pushing the red button (OFF).

Short-circuit protection is provided by the user through the application of fuses with a maximum value of 10A on electrical mains circuits.

Before connecting the concrete mixer to the mains, perform an external inspection of the electrical system, paying attention to its technical condition.

The power cord of the concrete mixer must be run in such a way as to not make it exposed to mechanical damage.

Perform a check of the technical conditions of power and control equipment of the concrete mixer at least once a year, this should consist of:

1. Checking the condition of the external insulation of electrical wires.
2. Checking the technical condition of the electrical auxiliary equipment (the condition of covers, switches, packing glands, whether the bolted connections of wire ends are loose or not).
3. Checking the continuity of electrical shock protection circuits.
4. Performing measurements on the protective circuit resistance.
5. Checking the technical condition of the electrical engine

In the case of finding any damage, remove the fault immediately. A periodical check of the whole electrical system, including the engine must be carried out at least once a year.

NOTE!

Checks and repairs of the electrical system must be performed by a qualified electrician.

Wyłącznik	Switch
-----------	--------

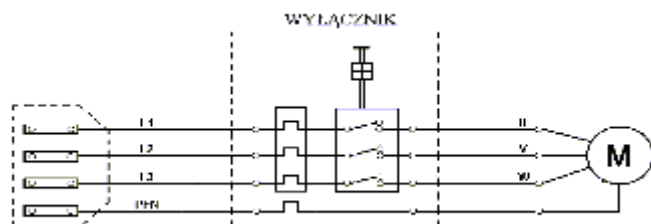

Figure 2

Diagram of the 3-phase electrical system

Wyłączniku typu: Tripus K900/TAZ/MOT/P	Tripus K900/TAZ/MOT/P switch
Typ silnika: SEh 80-4B/5953	Engine type: SEh 80-4B/5953

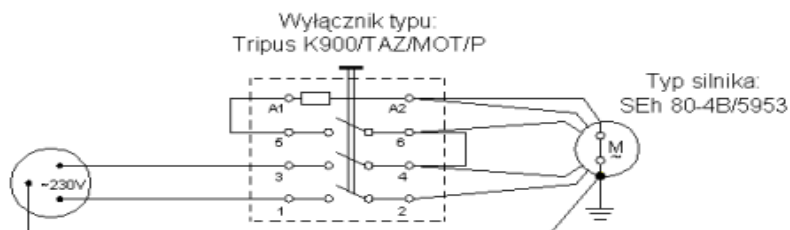

Figure No. 3

10	Wormwheel	8095/01-011	1	1	1	1
11	Tipping transmission housing	88095/01-008	1	1	1	1
12	Mixer frame	8095/01-003	1	1	1	1
13	60x80x10/40x75x10* sealing ring	PN-72/M-86964	1	1	1	1
14	32208/32207* bearing	PN-85/M-86100	1	1	1	1
15	Mixer axis	8095/01-005	1	1	1	1
16	z-24/z-19* lock ring	PN-81/M-85111	1	1	1	1
17	z-15/z-12* toothed wheel	8095/01-026	1	1	1	1
18	Slide sleeve	8095/01-015	1	1	1	1
19	6205/6204* bearing	8095/01-016	1	1	1	1
20	Bearing bracket	8095/01-027	1	1	1	1
21	6205/6204* bearing	8095/01-020	1	1	1	1
22	Drive shaft	8095/01-017	1	1	1	1
23	Engine belt pulley	8095/01-019	1	1	1	1
24	Enigne base	8095/01-018	1	1	1	1
25	z-122/z-135*toothed ring	8095/01-028	1	1	1	1
26	32207 bearing	PN-85/M-86100	1	1	1	1
27	Cover	8095/01-007	1	1	1	1
28	Mixing blade	8095/01-006	2	2	2	2
29	Mixer	8095/01-004	1	1	1	1
30	Drive cover	8095/01-021	1	1	1	1
31	Switch clamp	8095/01-023	1	1	1	1
32	TRIPUS IP57 switch	PN-92/E-06150	1	1	1	1
33	IP 57 Plug for a 400V/230V* engine	art. 3126 - 337	1	1	1	1
34	Belt pulley	8095/01-022	1	1	1	1
35	B-1500/A-950* V-belt		1	1	1	1
36	1.5kW/1.1kW* electrical engine	PN-IEC 34-1	1	1	1	1
37	Road wheel	8095/01-024	2	2	2	2
38	M24 nut	PN-74/M-82144	1	1	1	1
39	φ 24 washer	PN-78/M-82005	1	1	1	1

* refers to BWA-110 and BWA-80 concrete mixers

9. TROUBLESHOOTING

Table 3.

Fault type	Method of elimination
The engine does not switch on	- Check whether the connection to the system is performed properly - The film on the switch is too tight – make it looser
Dump transmission clearance	- tighten up the M8 screws connecting the cover with the transmission
Drum clearance	- tighten up M24 castellated nut and secure it - replacement of bearings on the drum roller
Z-15 wheel does not mesh in the ring	- lower Z-122 toothed ring, so that it meshes at $\frac{3}{4}$ of the tooth's height
loose V-belt	- V-belt tension

10. DISASSEMBLY AND DECOMMISSIONING

The disassembly of the concrete mixer consists in the removal of the joined elements from the machine, that is, screws, cotter pins, washers, until single elements are obtained. The used parts, which are not fit for recycling or re-use, must be taken to the scrap yard, and the plastic parts to a secondary raw material reception point, where they are disposed of in accordance with environmental protection principles. After disassembly and decommissioning, pay attention to the heavy elements of the device, so that they do not fall on the limbs, act in accordance with all the principles of caution.

11. LIST OF PARTS

Table 4.

No.	Part name	No. of KTM or standard No.	Number of pieces			
			BWA-200	BWA-150	BWA-110	BWA-80
1	Main frame	8095/01-001	1	1	1	1
2	Drawbar cotter pin	8095/01-025	1	1	1	1
3	Drawbar	8095/01-002	1	1	1	1
4	Tipper knob	8095/01-014	1	1	1	1
5	Worm shaft	8095/01-012	1	1	1	1
6	Worm	8095/01-010	1	1	1	1
7	Worm slide bearing	8095/01-013	1	1	1	1
8	Tipper transmission	8095/01-009	2	2	2	2
9	z-35/z-28* lock ring	PN81M85111	1	1	1	1

5. OPERATING MANUAL

5.1. Preparation for operation

Before the Gravity Concrete Mixer is switched on:

- Check the technical condition and completeness of the covers protecting the drive with the belt transmission
- check the electrical system in accordance with section 4.1 of this manual
- place the concrete mixer on a level surface
- set the drum of the concrete mixer in a working position for loading by turning the knob of the worm gear
- check the direction of the concrete mixer rotations, which should be in compliance with the direction of the arrow located on the external drum surface

The concrete mixer is started by pushing (green button) the switch (fig. 1 item 6). The time of mixing one charge is about 50-80 seconds.

The ready mix must be discharged when the concrete mixer is switched on and with the appropriate drum displacement by turning the knob of the worm gear. The concrete mixer is switched off by pushing the red button.

After emptying the drum, disconnect the power supply (pull out the plug from the socket) and wash it carefully.

5.2 Lubrication and maintenance

The Gravity Concrete Mixer has three points for lubrication with grease for LT-43 roller bearings. The sites, methods and frequency of lubrication are specified in table 1.

Table 1. Lubrication

No.	Lubrication site	Method of lubrication	Frequency of lubrication
1.	Drum frame support from both sides	Push the grease through the lubricating nipple	Every 100h of operation
2.	Worm gear of the mixer's tipping mechanism	Apply the grease with a spatula	Every 200h of operation
3.	Drive shaft bearings	Push the grease through the lubricating nipple	Every 100h of operation
4.	Mixer drum bearings	Apply the grease with a spatula	Every 200h of operation
5.	Road wheel hubs	Apply the grease with a spatula	Every 100h of operation

5.3. Completion of operation

After completing the operation of the concrete mixer:

- remove the plug from the mains socket,
- clean the concrete mixer from the residues of mixed substances,
- the sites where the varnishing surface is damaged, must be painted again with priming paint or surface emulsion after a prior cleaning and degreasing,
- in case any part is damaged, replace it with one that is free of defects.

5.4. Replacement of parts

The most frequently used parts, which are not covered by the guarantee include the toothed wheels that drive the ring, the toothed ring, wormwheel, belt pulley, sealing rings and bearings.

In the case of longer shut-downs of the concrete mixer (e.g. winter period, before it is restarted, check the correctness of connections of the neutral conductor in plug-in sockets and plugs.

5.5 Repairs

The aim of repairs is to bring back the technical condition determined by the manufacturer:

- A ‘minor repair is a repair with an individually established scope, consisting in the elimination of faults and insignificant damage of the concrete mixer subassemblies, noticed during the daily technical operation or periodical technical operation. The current repair may be conducted at the working site of the concrete mixture.
- A ‘major’ repair is a planned repair consisting in bringing the concrete mixer to the technical condition assumed by the manufacturer to maintain the capacity to function throughout the next inter-repair period. The first major repair and the next ones must be carried out after operation for about 5000 working hours. The scope of activity for the major repair covers: the complete disassembly, washing of parts, verification of parts and conducting investigations into parts that are subject to replacement, repair, reuse in the current state, repair of damaged parts, assembly of the concrete mixer, adjustment, application of anticipated protective paint-coats, lubrication of sites specified in table 1 and conducting post-repair tests.

6. STORAGE

The gravity concrete mixer must be stored in conditions providing protection from corrosion and other damage. Strong attention must be paid to the protection of the engine and auxiliary equipment from atmospheric conditions and factors.

7. TRANSPORT

The Gravity Concrete Mixer is equipped with road wheels as well as a holder to move it short distances within the working area, with a speed that is not greater than 10 km/h.

The concrete mixer may be transported longer distances only on a platform of any means of transport. For the period of transport, the concrete mixer must be protected from movement and mechanical damage.

8. TECHNICAL CHARACTERISTICS

Table No. 2

Specification	BWA-200	BWA-150	BWA-110	BWA-80	Unit of measure
Sizes:					
- height (H),	1600	1500	1450	1370	mm
- width (S),	1150	1150	670	670	mm
- min. distance (D ₁).	1650	1650	1400	1400	mm
- max. distance (D ₂)	2200	2200	1900	1900	mm
Loading height	1300	1100	1100	1050	mm
Unloading height	550	520	520	550	mm
Working capacity	200	150	110	80	dm ³
External drum diameter	770	770	600	600	mm
Discharge hole diameter	390	390	350	350	mm
Concrete mixer drum revolutions	28	28	28	28	rev./min.
Efficiency	3	2,4	1,5	1,0	m ³ /h
Own power	240	200	120	100	kg
Electrical engine:					
- type	Sg904S	Sg904S	Seg804S	Seg804S	
- power	1.5	1,5	1.1	1.1	kW
- revolutions	1415	1415	1415	1415	rev./min.
- voltage	400	400	230	230	V
Electrical wire length:					
- from the engine to the switch:	0.4	0.4	0.4	0.4	m
- from the switch to the plug:	1	1	1	1	m